



Tasmanian Timber Flooring Installation Guides

Tasmanian hardwood timber strip flooring on joists & overlay flooring guides for installers.



tasmaniantimber.com.au

ORIGINAL

TASMANIAN
TIMBER™

Tasmanian Hardwood Strip Flooring on Joists

Installation Guide

These instructions apply to quality Tasmanian strip flooring fixed over joists in residential applications.

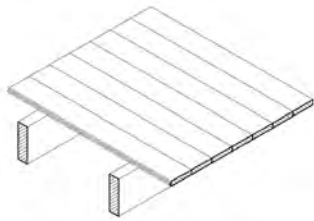

Strip Floor on Joists

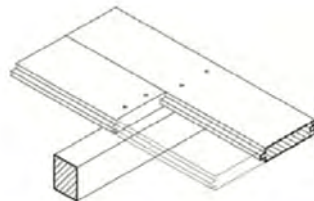

Top Nailed

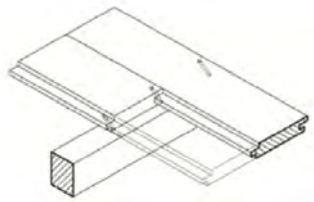

Secret Nailed

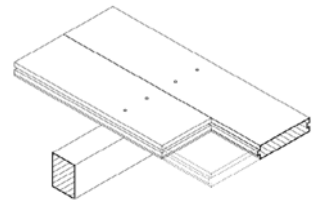

End Matched

Tools

Simple tools are adequate in most applications.

✓ Tool Requirement Checklist	
Pencil, tape measure and square	Hammer, punch and nail bag
Stringline, spirit level and straight edge	Hand saw and jig saw
Safety glasses, dust mask and knee pads	Spacers (about 100 mm long and 2 mm thick)
Rubber mallet, broom and vacuum cleaner	Framing chisel

For specialist applications, a drop saw, an air power staple gun, a power actuated fastener system and a cramping system may be useful.

Materials

Use quality boards of the correct thickness.

Grade descriptions for strip flooring are set out in the Australian Standard AS 2796 and are available at:

tasmaniantimber.com.au

Boards at least 19 mm thick are needed to span 450 mm.

Board width—Only secret nail boards up to 85 mm cover width. Secret nailed flooring is fixed through the tongue of specially profiled boards. Since they are only secured with one fastener per joist or batten, their width is limited to 85 mm cover. Board over 85 cover must be top nailed with two fasteners per joist.

Use the correct nails for the job.

The nail sizes required by Australian Standard 1684 are:

Nail sizes for T & G flooring to joists*		
Nailing	Softwood joists	Hardwood & cypress joists
Hand driven	65 x 2.8 mm bullet head	50 x 2.8 mm bullet head
Machine driven	65 x 2.5 mm	50 x 2.5 mm

Nail sizes for T & G flooring to plywood substrate*	
Strip flooring thickness (mm)	Rec. nailing (min.15 mm substrate)
19 or 20	38 x 16 gauge chisel point staples or 38 x 2.2 mm nails at 300 mm spacing
12, 19 or 20	32 x 16 gauge chisel point staples or 30 x 2.2 mm nails at 200 mm spacing

Notes

*Alternative fasteners can be used for substrate types not listed subject to manufacturers' recommendation.

Any glue used is in addition to the correct nailing. Use only specialist elastomeric glues. Where vibration or dynamic loading is of concern, gluing the flooring to the joists may reduce later movement. Even if glued, the floor still needs to be fully nailed. Do not use hard setting glues.



tasmaniantimber.com.au

ORIGINAL

TASMANIAN
TIMBER™

Tasmanian Hardwood Strip Flooring on Joists Installation Guide

Moisture Content of the Timber

Timber is a natural product. Its dimensions vary with changes in surrounding moisture:

As timber absorbs moisture to remain in equilibrium with its surrounding atmosphere, it expands. As it loses moisture, it shrinks. Strip flooring will always move slightly between boards as the ambient conditions of the surrounding environment change. So, to produce a successful timber floor, the timber needs to be installed at the correct moisture content, changes in the ambient conditions controlled and any movement accommodated.

The moisture content of the timber at time of laying is very important:

Test the moisture content (MC) of at least 5 randomly selected boards with a resistance moisture meter when the timber is delivered or insist the supplier provides readings. Readings from the meter must be corrected for species and temperature with correction factors available at: tasmaniantimber.com.au Australian Standard AS2796 requires moisture contents between 9 and 14%. Laying material that is too wet or too dry may cause problems later.

If necessary, allow the timber to acclimatise to long term service conditions:

Typically, timber supplied to the Standard should have a moisture content suitable for normal temperature and humidity conditions in most locations.

Where service conditions vary considerably from normal, such as in air-conditioned, centrally heated or hot sunny rooms, the timber should be acclimatised by racking it out in the room with strips between each row of boards. The timber should be left with the heating or air conditioning running, until the moisture content is satisfactory.

The more the expected service conditions in the room vary from normal, the longer the boards need to be acclimatised.

Timber	Service Environment	Response & Required Action
Flooring supplied at a moisture content usually between 10% and 12%	Moist Conditions Average MC between 12.5-16% Cool & damp or hot & very humid	Timber expands • Provide extra expansion joints • Acclimatise
	Normal Conditions Average MC between 10-12.5%	Timber remains relatively stable.
	Dry Conditions Average MC between 8-10% Air conditioned, centrally heated, or rooms with large northern windows	Timber contracts • Acclimatise • Consider alternatives to polyurethane finishes

Storage

Protect the timber from moisture during all stages of construction:

Avoid exposing the timber to rain, dew or direct sunlight. Keep it away from the ground or newly laid concrete. Repair damage to pack covers immediately.

The flooring should be stored in a fully enclosed area where it is to be laid, or in a similar environment.

Handle the timber carefully:

Protect the upper surfaces and the tongues of the boards from damage.



Tasmanian Hardwood Strip Flooring on Joists Installation Guide

Preparation

Only install the flooring in a fully weatherproofed building:

The roof should be on, windows & external doors installed, exterior cladding finished and wet trades complete. The storm water system must be complete or effectively taking water away from the sub-floor or slab.

Do not lay the floor if there is any sign of water entering the work area.

Provide under floor ventilation to the requirements of the Building Code of Australia as a minimum:

The ground under the floor should be dry and the sub-floor well ventilated. In renovation projects, clear existing ventilators or install additional ventilators in the perimeter walls.

Where conditions under the floor are damp & the potential for additional drainage or ventilators limited, install a continuous impervious plastic membrane over the ground and fixed up the perimeter walls. Lap and tape the joints. The space above this barrier must still be ventilated.

Floor framing should be solid, level, true and preferably seasoned:

The tops of framing members should be flat & sound. Place a 3 m straight edge along & across the top of joists. Variation should not exceed 3 mm. Plane proud joists & pack low ones.

Install required insulation and draught barriers:

The Building Code of Australia now includes thermal performance requirements for housing. Complying with these may involve insulating the timber floor. The major insulation options are:

- Reflective and moisture permeable foil draped over the joists, or fixed underneath them.
- Bulk insulation, such as insulation batts, packed between the joist on the foil or other support such as wire mesh.
- Proprietary folded foil and expanded foam products fixed between the joists.

Details of these options and the rating achieved are available at: tasmaniantimber.com.au

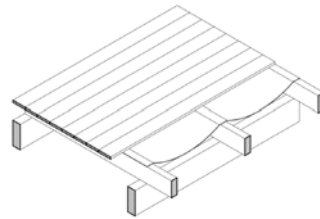

Permeable Foil on Joists

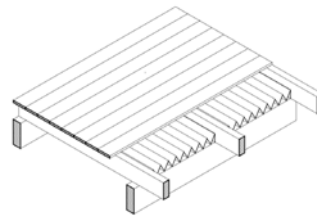

Folded Foil Between Joists

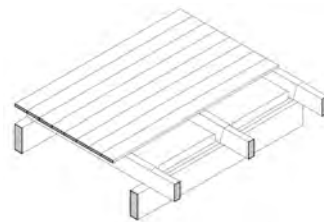

Bulk Insulation on Foil

Keep the site and work area clear and clean:

Clean and vacuum the substrate. Arrange the work area so that sawdust from cutting boards is excluded from where boards are laid. Put unneeded tools away.



tasmaniantimber.com.au

ORIGINAL

TASMANIAN
TIMBER™

Tasmanian Hardwood Strip Flooring on Joists Installation Guide

Sanding & Coating

Prepare the floor thoroughly:

The quality of the finished timber floor depends heavily on the quality of the surface preparation. Ensure that all exposed nails are punched adequately. Fill any holes or gaps with a filler compatible with the floor finish.

Select the coating system to suit the project:

- *Moisture curing and 2 pack polyurethanes* produce a clear, very hard-wearing surface in a matt, satin or high gloss finish. However, they darken with age. If applied to a poorly laid or unstable floor, they can also glue the tongue of one board into the groove of the next.
- *Water-based polyurethanes* can produce a clear, hard-wearing surface in a matt, satin or gloss finish. While more expensive, they produce less fumes during application and curing, and are trafficked earlier. They can also glue boards in an unstable floor together.
- *Modified oil coatings* are clear varnishes, generally made from a mixture of resin and oil. Easy to apply and penetrating, these give a slightly softer look than polyurethanes but are less hard wearing and darken with age. A surface polish is recommended to reduce maintenance in high traffic areas.
- *Oils* are penetrating finishes that are generally less hard wearing than the modified oils or polyurethanes. They give a soft, natural appearance but require regular maintenance.

Employ professional sanding and finishing contractors:

The floor needs to be sanded to a flat and level surface. Deep scratch marks should not be present or accepted. Equally, do not expect a “furniture quality” finish on site.

Finishing

Follow the finish manufacturer’s instructions exactly:

Many problems with timber floors are due to inappropriate application of the finish. Do not thin the finish unnecessarily. Only apply polyurethane or two part coatings to tight, well-laid floors at the correct moisture content. These coatings can glue boards together, causing ‘clumping’, ‘slabbing’ or other problems later.

Care

Fit protective pads to your furniture:

Timber floors are resilient but they can be scratched by moving furniture or high point loads. Inspect the bottom of lounges, chairs and sideboards. Some older furniture has metal buttons on the base of legs. Remove these. Fit adhesive felt and other soft pads to all legs and supports that will sit on the floor. The hard plastic feet on some stools can dent the timber. If this occurs, fit softer rubber pads.

Minimise dust:

Dust on the floor can scratch the surface of the finish, especially in high traffic areas. Install coir mats at doors. Vacuum and sweep regularly.

Wipe off marks with a damp cloth:

Most marks can be removed without the use of abrasives or chemicals. Do not wet mop the floor as it can lead to problems with the timber.

Clean up spills quickly:

Occasional spills should not significantly influence the floor if they are wiped up immediately. Persistent leaks from sinks or dishwashers will cause problems. They should be fixed immediately.



Tasmanian timber is sustainably grown, harvested and processed to meet the highest standards in quality and environmental practice.

For further information contact:

Locked Bag 1324, Launceston, Tasmania, 7250
Phone: 1300 041 766 – (international callers: +613 6324 4081)
Email: contact@tasmaniantimber.com.au

tasmaniantimber.com.au



Tasmanian Hardwood Strip Flooring on Joists Installation Guide

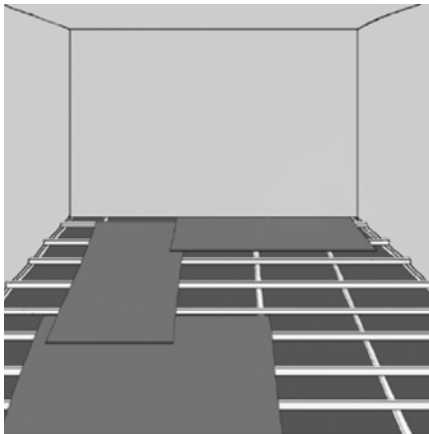

1.

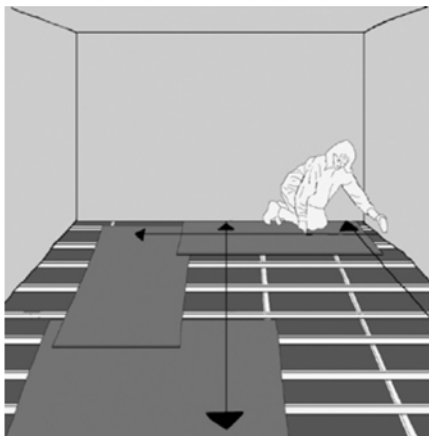

2.

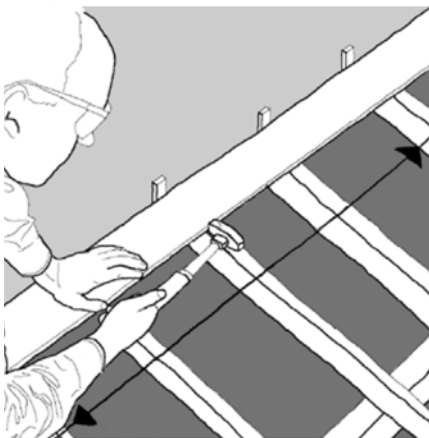

3.

1. Keep the site and work area clear, clean and safe.

Sweep the top of the joists.

Put unneeded tools away. Arrange the work area so that sawdust from cutting boards is excluded from where boards are laid.

Establish a safe temporary working platform and walkways over the open floor joists. These can be repositioned or removed as the floor is laid.

Install any insulation or draught barrier.

2. Set out the exact line of the boards.

Use a string line, tape and square to check that the sides of the room are parallel.

Decide on the exact line of the rows of boards to suit the room's shape. Remember that boards need to span as near to right angles to the line of the joists as possible.

Set this line out and mark it as the string line near the centre of the room.

Set up a second string line at least the width of two boards away from the wall. This line **MUST** be exactly parallel to the reference line in the middle of the room.

3. Plan expansion gaps at the perimeter of floors & intermediate gaps in floors over 6 m wide.

A minimum 10 mm gap is needed between the edge of the boards & any vertical barrier such as walls.

Floors over 6 m wide need intermediate expansion gaps at a rate of 10 mm per 6 m width across the boards. These can be located at thresholds or spaced evenly throughout the floor as a series of smaller gaps.

Use 2 mm spacers between rows of boards about 1.2 m apart to form these expansion gaps.



Tasmanian Hardwood Strip Flooring on Joists Installation Guide

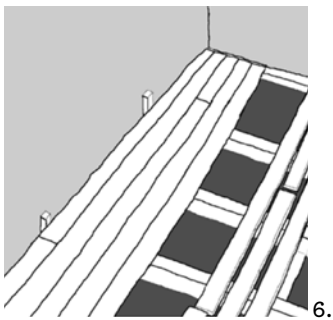
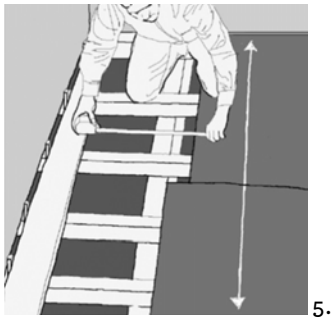
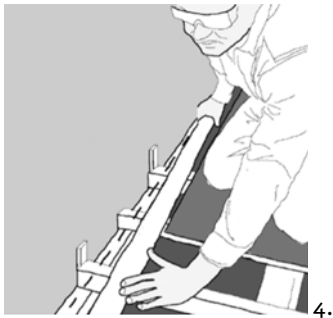

4. Set out the first board carefully.

Select long straight boards for the first row. For boards that are not end matched, square cut them so that butt joints occur at the centre of the joists. The boards must bear at least 12 mm onto the joist.

If the end wall is not parallel to the string set out line, profile the boards so that any remaining gap is covered by the skirting board.

Position the first row of boards approximately in place, parallel to the set out line. Check that the expansion gap is sufficient. Make sure the boards clear any obstructions.

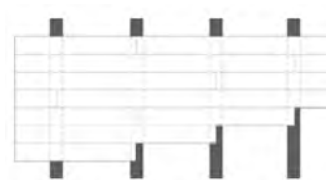

Fig 1. Butt joints over joist for boards that are not endmatched.

5. Install the first board carefully.

Starting from one end of the row, position the end of the first board in exactly the right position, leaving the necessary expansion gap.

Single nail that end in place. If top nailing, do not drive the nail home.

Carefully measure the distance from the string set out line to the fixed end of the board.

Move to the other end of the board and position it at exactly the same distance from the set out line. Fix it into place.

Repeat this at the centre of the same board, then at each joist. Continue with next board in the row until the first row is complete and solidly fixed in place. Ensure any butt joints are tight.

If necessary, use packers to block this row off the end wall so that it will not move as subsequent rows are cramped into position.

6. Lay boards in straight and parallel lines.

Cut and arrange about 5–8 full rows of boards ready for laying. Sort the boards so that butt joints in adjacent rows are a minimum of 450 mm apart and are distributed evenly throughout the floor. With end matched boards, position site-cut ends near the wall. Use the full length and the machined ends of boards where possible.

Ensure joints in adjacent rows of end matched boards do not fall in the same joist spacing.

Boards need to be at least two joist spacings long. Use shorter pieces at the ends of the rows.

Select boards to spread any colour variation evenly through the floor.

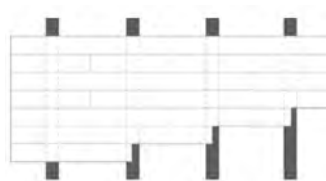
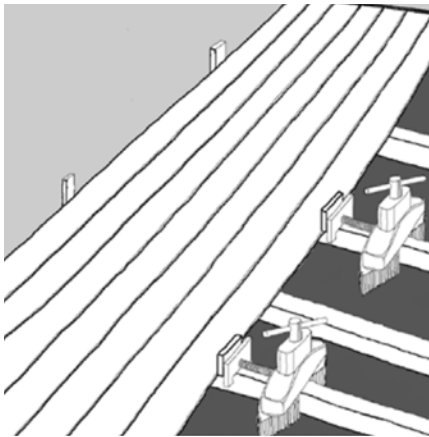

Fig 2. Butt joints for end matched boards.



Tasmanian Hardwood Strip Flooring on Joists Installation Guide



7. Position boards carefully and cramp tight.

Top nailed boards can be clamped with a cramping system, or with a chisel.

Always protect the tongue of the board with an offcut. If using a cramping system, cramp no more than 800 mm width of flooring at a time. If clamping with a chisel or other hand lever, cramp no more than 5 rows of boards at a time.

Cramp boards tight working from one end of the row closing any gaps.

As the boards are cramped, knock the top surface of the boards with a rubber mallet. This helps seat the tongue and groove home.

Nail the leading board at each joist as it is cramped.

Again do NOT drive the nail fully home.

Ensure all butt joints are tightly closed. Push them in from the end if necessary.

For secret nail boards, cramp each board tight or use specialist fastening guns. Fully nail them as they are laid.

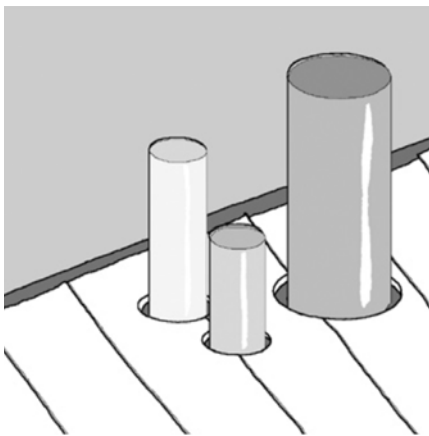

8. Cut around any pipes or penetrations.

Mark the boards carefully and cut them with a hole or jig saw.

Boards should finish 10 mm clear of the penetration or pipe.

9. Use the correct number and length of fasteners.

Australian Standard 1684 establishes min. fastener dimensions for fixing flooring to joists. These are set out in the Materials section above.

Boards over 85 mm cover width MUST be surface nailed with two nails per joist.

If glue is used, it must be additional to the correct nailing.

Gluing the flooring to the joists is generally not necessary.

If it is glued, the flooring still needs to be fully nailed.

Only use specialist elastomeric glues. Do not use hard setting glues.



Tasmanian Hardwood Strip Flooring on Joists Installation Guide

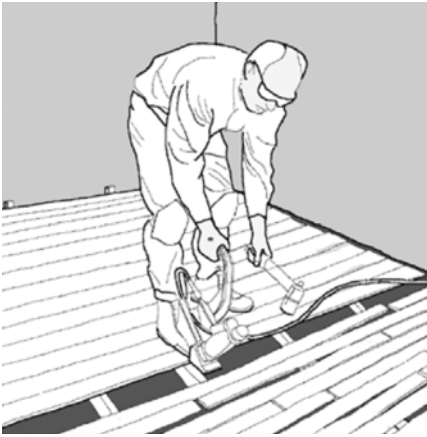

10.



11.



12.

10. Repeat the process until the floor is complete.

Incorporate intermediate expansion gaps if they are required. For surface nailed boards, the floor must now be fully nailed. Boards should be in full contact with the floor frame as they are nailed.

Keep the nail lines straight. Skew consecutive nails in opposing directions.

Nail at least 12 mm from the end of boards. Depending on the species, nailing near the end may cause splitting. If this occurs, pre-drill those nail holes to 80% of the nail diameter.

Take care driving the nails home, as a missed swing of the hammer may dent the timber.

11. Prepare the floor thoroughly.

The quality of the finished timber floor depends heavily on the quality of the surface preparation.

Punch all exposed nails a minimum of 3 mm below the surface of the boards.

Fill the nail holes with a filler compatible with the floor finish.

12. Protect the boards prior to sanding and finishing.

Plasterboard setting compounds can stain timber & silicone sealants and glues can affect the bond of the finish.

Scaffolding, ladders, & dropped tools can dent timber significantly.

Cover the completed floor with cardboard, plastic and drop sheets.



Tasmanian Hardwood Overlay Flooring Installation Guide

These instructions apply to quality Tasmanian strip flooring used as an overlay on a structural substrate in residential applications.

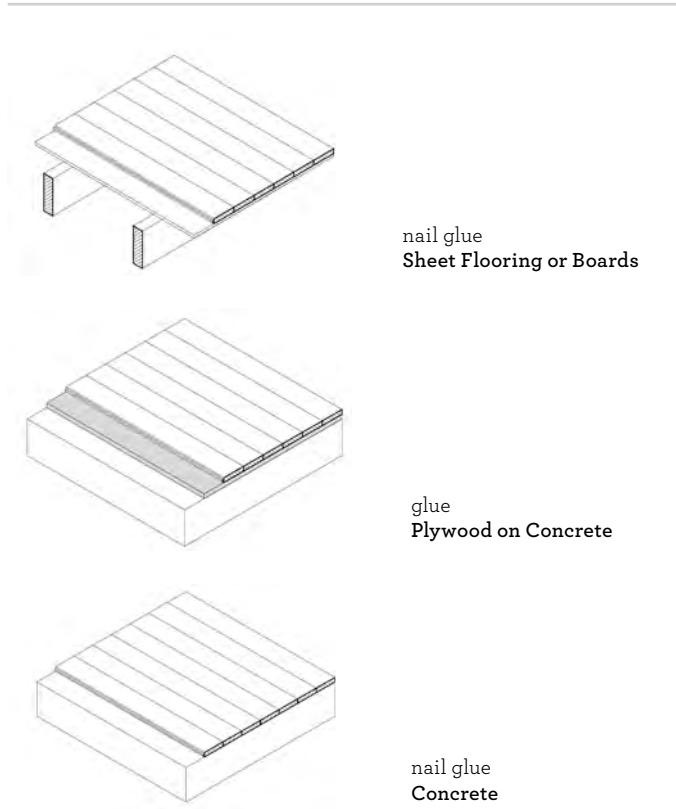

nail glue
Sheet Flooring or Boards

glue
Plywood on Concrete

nail glue
Concrete

Tools

Simple tools are adequate in most applications:

Necessary tools are:

✓ Tool Requirement Checklist	
Pencil, tape measure and square	Hammer and nail bag
Stringline, spirit level and straight edge	Hand saw and jig saw
Safety glasses, dust mask and knee pads	Spacers (about 100 mm long and 1 & 2 mm thick)
Glue spreader	Broom and vacuum cleaner

For specialist applications, a drop saw, an air power staple gun, a power actuated fastener system, and a cramping system may be useful.

Materials

Use quality boards of the correct thickness:

Product and grade descriptions for strip flooring are set out in the Australian Standard AS 2796 and are available at: www.tastimber.tas.gov.au. 12–13 mm thick tongue and groove boards must be continuously supported on a structural substrate, such as plywood or concrete, or on closely spaced battens. If boards are fixed directly to joists, they need to be at least 19 mm thick to span 450 mm.

Board width for nail only application – Only secret nail boards up to 85 mm cover width:

Secret nailed flooring is fixed through the tongue of specially profiled boards. Since they are only secured with one fastener per joist or position, their width in nail only applications is limited to 85 mm cover.

Use only specialist elastomeric glues:

Do not use hard setting glues. Flooring glues need to allow for movement in the timber. Companies that make them include Bostik, Toby, Fullers and Ramset. Follow the manufacturer's recommendations exactly.

Use compatible levelling, sealing and gluing products:

Manufacturers develop products to work as a system. Mixing brands of products can cause incompatibility problems and void guarantees. Follow the manufacturer's recommendations exactly.

Use the correct nails for the job:

Use 30 mm concrete nails with washers for fixing overlay to concrete. If the boards are not being glued, the nail sizes required by Australian Standard 1684 are:

T & G flooring to plywood substrate	
Flooring thickness	Rec. nailing (min. 15 mm subfloor)
19 or 20	38 x 16 gauge staples or 38 x 2.2 mm nails at 300 mm spacing
12, 19 or 20	32 x 16 point staples or 30 x 2.2 mm nails at 200 mm spacing

Notes

*Alternative fasteners can be used for substrate types not listed subject to manufacturers' recommendation.



Tasmanian Hardwood Overlay Flooring Installation Guide

Moisture Content of the Timber

Timber is a natural product. Its dimensions vary with changes in surrounding moisture:

As timber absorbs moisture to remain in equilibrium with its surrounding atmosphere, it expands. As it loses moisture, it shrinks. Strip flooring will always move slightly between boards as the ambient conditions of the surrounding environment change. To produce a successful timber floor, the timber needs to be installed at the correct moisture content, changes in the ambient conditions controlled and any movement accommodated.

The moisture content of the timber at time of laying is very important:

Test the moisture content of at least 5 randomly selected boards with a moisture meter when the timber is delivered or insist the supplier provides readings. Reading from the meter must be corrected for species and temperature with correction factors available at: tasmaniantimber.com.au

Unless agreed with the supplier, reject the material if corrected moisture content readings are over 14% or under 9%. This is outside the Australian Standard.

If necessary, allow the timber to acclimatise to long term service conditions:

Typically, timber supplied to the Standard should have a moisture content suitable for normal temperature and humidity conditions in most locations.

Where service conditions vary considerably from normal, such as in air-conditioned, centrally heated or hot sunny rooms, the timber should be acclimatised by racking it out in the room with strips between each row of boards. The timber should be left with the heating or air conditioning running, until the moisture content is satisfactory.

The more the expected service conditions in the room vary from normal, the longer the boards need to be acclimatised.

Timber	Service Environment	Response and Required Action
Flooring supplied at a moisture content between 10% and 12%	Moist Conditions Average MC between 12.5 – 16% Cool & damp or hot & very humid	Timber expands • Provide extra expansion joints • Acclimatise
	Normal Conditions Average MC between 10 – 12.5%	Timber remains relatively stable.
	Dry Conditions Average MC between 8–10% Air conditioned, centrally heated, or with large northern windows	Timber contracts • Acclimatise • Consider alternatives to polyurethane finishes

Storage

Protect the timber from moisture during all stages of construction:

Avoid exposing the timber to rain, dew or direct sunlight. Keep it away from the ground or newly laid concrete. Repair damage to pack covers immediately.

Ideally, the flooring should be stored in a fully enclosed area where it is to be laid, or in a similar environment.

Handle the timber carefully:

Protect the upper surfaces and the tongues of the boards from damage.



Tasmanian Hardwood Overlay Flooring

Installation Guide

Preparation

Only install the flooring in a fully weatherproofed building:
The roof should be on, windows and external doors installed, exterior cladding finished and wet trades complete. The storm water system must be complete or effectively taking water away from the sub-floor or slab.
Do not lay the floor if there is any sign of water entering the work area.

Substrates must be dry:

Concrete slab must be dry, with a moisture content no more than 5.5%. This can be measured with a hygrometer moisture test. An alternative method is to seal a 450 mm square sheet of plastic or glass to the slab. If the slab darkens or there is any condensation after a day, the slab is too wet to install the floor. It must be left to dry out or be sealed.

Whatever their age, all slabs should be regarded as a source of moisture. If in doubt or if there is evidence of previous water penetration:

- seal the slab with a proprietary waterproofing compound; or
- install a 0.2 mm plastic membrane under a plywood underlay.

Lay the plastic over the whole of the floor, overlap the joints by 200 mm and tape them. Lay the plywood so that the sheets run 900 to the intended direction of the board and fix with 2.9 mm concrete nails. Space these 100 mm in from the edge and at 550 mm centres along the grain and 500 mm across the grain.

Do not lay the flooring directly on a damp slab.

Sheet flooring or boards:

Sheet flooring or boards must be dry, with a moisture content no more than 14 %. This can be measured with a resistance moisture meter.

The ground under sheet or board substrates should be dry and sub-floor ventilated to the requirements of the Building Code of Australia as a minimum. In renovation projects, clear existing ventilators or install additional ventilators in the perimeter walls. Where conditions under the floor are damp and the potential for additional drainage or ventilators limited, install a continuous impervious plastic membrane over the ground and fixed up the perimeter walls. Lap and tape the joints. The space above this barrier must still be ventilated.

Substrates should be solid, level, true and provide a good key for gluing:

Surfaces should be flat and sound. Check the surface with an automatic level or a level and a straight edge. The variation from a 3 m straight edge should not exceed 3 mm. Level uneven surfaces with a levelling compound. Follow the manufacturer's recommendations exactly.

Concrete:

If the surface of the concrete is crumbly or broken, install a plywood underlay as described above. If the surface is generally sound, patch any local surface damage.

Sheet flooring or boards:

Skim sand existing boards or sealed particleboard and plywood floors to provide a clean, flat gluing surface. Plug any holes and repair any damage to the surface. If the floor squeaks, force a bead of elastomeric glue into the joint between the top of the joists and the flooring.

Keep the site and work area clear and clean:

Clean and vacuum the substrate. Arrange the work area so that sawdust from cutting boards is excluded from where boards are laid. Put unneeded tools away.



Tasmanian Hardwood Overlay Flooring Installation Guide

Sanding & Coating

Prepare the floor thoroughly:

The quality of the finished timber floor depends heavily on the quality of the surface preparation. Ensure that all exposed nails are punched adequately. Fill any holes or gaps with a filler compatible with the floor finish.

Select the coating system to suit the project:

- *Moisture curing and 2 pack polyurethanes* produce a clear, very hard-wearing surface in a matt, satin or high gloss finish. However, they darken with age. If applied to a poorly laid or unstable floor, they can also glue the tongue of one board into the groove of the next.
- *Water-based polyurethanes* can produce a clear, hard-wearing surface in a matt, satin or gloss finish. While more expensive, they produce less fumes during application and curing, and are trafficable earlier. They can also glue boards in an unstable floor together.
- *Modified oil coatings* are clear varnishes, generally made from a mixture of resin and oil. Easy to apply and penetrating, these give a slightly softer look than polyurethanes but are less hard wearing and darken with age. A surface polish is recommended to reduce maintenance in high traffic areas.
- *Oils* are penetrating finishes that are generally less hard wearing than the modified oils or polyurethanes. They give a soft, natural appearance but require regular maintenance.

Employ professional sanding and finishing contractors:

The floor needs to be sanded to a flat & level surface. Deep scratch marks should not be present or accepted. Equally, do not expect a “furniture quality” finish on site.

Finishing

Follow the finish manufacturer’s instructions exactly:

Many problems with timber floors are due to the inappropriate application of the finish. Do not thin the finish unnecessarily. Only apply solvent based polyurethane or two part coatings to tight, well-laid floors at the correct moisture content. These coatings can glue boards together, causing ‘clumping’, ‘slabbing’ or other problems later.

Care

Fit protective pads to your furniture:

Timber floors are resilient but they can be scratched by moving furniture. Inspect the bottom of lounges, chairs and sideboards. Some older furniture has metal buttons on the base of legs. Remove these. Fit adhesive felt and other soft pads to all legs and supports that will sit on the floor. The hard plastic feet on some stools can dent the timber. If this occurs, fit softer runner pads.

Minimise dust. Vacuum and sweep regularly:

Dust on the floor can scratch the surface of the finish, especially in high traffic areas. Install coir mats at doors. Vacuum and sweep regularly.

Wipe off marks with a damp cloth:

Most marks can be removed without the use of abrasives or chemicals. Do not wet mop the floor as it can lead to problems with the timber.

Clean up spills quickly:

Occasional spills should not significantly influence the floor if they are wiped up immediately. Persistent leaks from sinks or dish-washers will cause problems. They should be fixed immediately.

For further information contact:

Centre for Sustainable Architecture
with Wood University of Tasmania
Phone: 03 (int+613) 6324 4470
Email: timber@arch.utas.edu.au

tasmaniantimber.com.au



Tasmanian timber is sustainably grown, harvested and processed to meet the highest standards in quality and environmental practice.

Tasmanian Hardwood Overlay Flooring Installation Guide

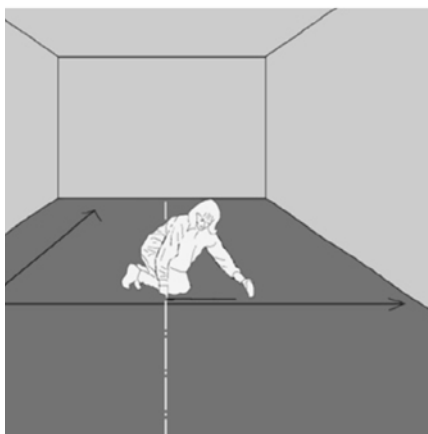

1.

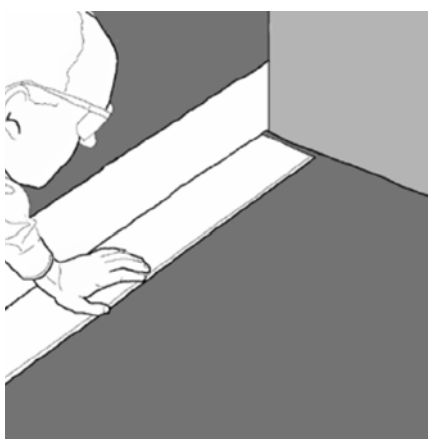

2.

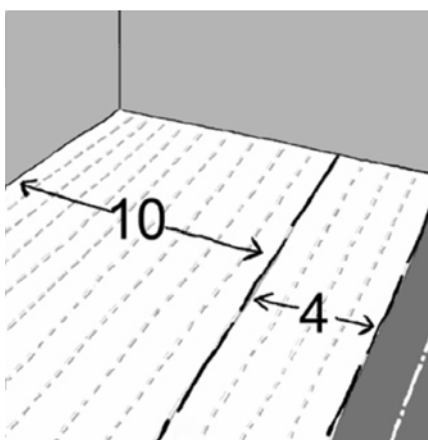

3.

1. Plan and set out the board direction.

Before you begin, clean up the site and work area. Put unneeded tools away.

Use a stringline, tape and square to check the exact shape of the room and if the sides of the room are parallel.

Decide on the exact line of the rows of boards to suit the room's shape.

Set this line out as a stringline and mark it as the reference line near the centre of the room.

Take off existing skirting boards and trim door frames and architraves if necessary.

Concrete

The concrete should be clean, level and dry.

If not, see *Preparation*

Sheet flooring or boards

Overlay boards should be laid at right angles to the board direction of existing board floors and at least 450 to the long edges of existing particleboard or plywood floors.

2. Plan intermediate expansion gaps in floors over 6 m wide.

A minimum 10 mm gap is needed between the edge of the boards and any vertical barrier such as walls.

Floors over 6 m wide need intermediate expansion gaps at a rate of 10 mm per 6 m run across the boards.

These can be located at thresholds or spaced evenly throughout the floor as a series of smaller gaps.

Use spacers about 2 mm thick between rows of boards about 1.2 m apart to form these smaller expansion gaps.

Tip

Cut the boards in a separate work area. Keep dust or debris off the substrate and away from any glue.

3. Set out the position for the first row of boards.

Working from the reference line and position of any planned expansion joints, set out another stringline, the board set out line, that is:

- about 10 board widths away from one end wall
 - exactly parallel to the reference line in the middle of the room.
- Then, set out another string line, a gluing line, towards the centre of the room 4–6 board widths away from and parallel to the board set out line.



Tasmanian Hardwood Overlay Flooring

Installation Guide



4.

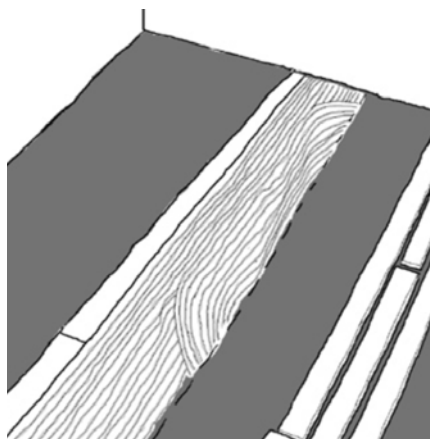

5.



6.

4. Use the full length and machined ends of boards where possible.

Cut and arrange 4–6 full rows of boards ready for laying.

Sort the boards so that butt joints in adjacent rows are a minimum of 450 mm apart.

Use shorter pieces at the ends of the rows.

Select boards to spread colour variation evenly though the floor.

Spread the glue at the recommended rate

Apply glue between the board set out line and the gluing line.

Work up to the lines carefully starting at one end and then along the line to the other.

Make sure the board set out line is still visible.

5. Lay the first board carefully.

Select long straight boards for the first row.

Position the first row of boards approximately in place along the board set out line with the groove to the line.

Starting from one end of the row, position the end of the first board exactly on the board set out line and fix.

On concrete, fix the first row with concrete nails.

On sheet flooring or boards, fix with nails into the substrate.

Move to the other end of the same board and position it exactly on the board set out line. Fix it into place.

Repeat this at the centre of the same board.

Continue with next board in the row until the first row is complete and solidly fixed in place. Ensure any butt joints are tight.

This board needs to be fixed securely so that it will not move when later boards are cramped up to it.

6. Position boards carefully in the glued area and nail.

Lay boards in place against this initial row until all the rows in the glued area between the board set out line and the gluing line are laid.

Position boards carefully as near as possible to their final position so the glue is not squeezed up between the boards as they are moved into place. Push or tap them into place with a timber block or offcut.

Ensure all end joints are tightly closed and distributed evenly throughout the floor. Push them in from the end if necessary.

If the boards do not close up tight, check for debirs between the boards.

Close any gaps in the boards, cramping the boards of a wall if possible.

Fix the last row of boards in the panel with nails, leaving concrete nails protruding so that they can be easily removed later.

If secret nailing, cramp and fix each board tightly as it is laid.



Tasmanian Hardwood Overlay Flooring Installation Guide



7.

7. Use the correct number and length of fasteners.

Australian Standard AS 1684 establishes minimum fastener dimensions for fixing flooring without glue. These are set out in the Materials section.

In nail-only applications, boards over 85 mm cover wide should be nailed with two nails per joist.

Tip

Use no more than three concrete nails in one small area. If the nails won't hold a board down, then use a weight until the glue has cured.

8. Cut around any pipe or penetrations.

Mark the boards carefully and cut them with a hole or jig saw. Boards should finish 10 mm clear of the penetration or pipe.

Tip

When gluing a timber floor, do not work with any more than 4–6 rows of boards at a time as the glue can skim over and its effectiveness is reduced. Any glue protruding from an area that will not be worked with for some time should be removed.

9. Repeat the process until the floor is almost complete.

Work off the laid boards with about 4–6 rows at a time. Mark a gluing line from the edge of the laid boards each time, apply the glue at the required rates up to it, then lay and fix the boards.

Incorporate intermediate expansion gaps if they are required. Work until the floor is laid to about two boards away from each wall.

Concrete

Restrain the rows with enough removable concrete nails to hold the boards tight.

Sheet flooring or boards

Continue to secret nail or surface nail as you lay the rows.

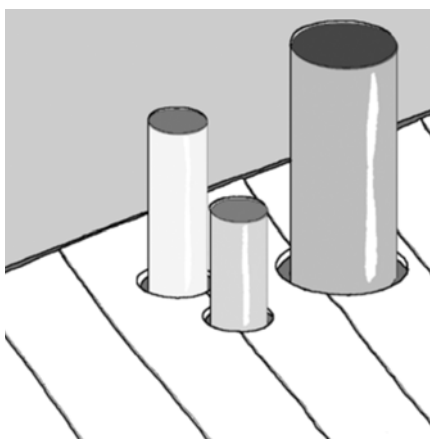

8.



9.



Tasmanian Hardwood Overlay Flooring Installation Guide



10.

10. Set out the last boards carefully.

Select long straight boards for the last rows.

Without applying any glue, position the last row of boards approximately in place.

Make sure the flooring clears any obstructions.

Generally, the last row of boards will have to be cut along their length to complete the floor.

Remember that a minimum 10 mm gap is needed between the edge of the boards and any vertical barrier such as a wall.

Using a ruler or tape, scribe the line of the wall onto the last boards so that when cut, they will fit in the remaining space.

Remove the last boards and cut to the line.

Position them against the wall and check that the final boards fit neatly, clearing any obstructions.

Remove the final boards and any dust or debris on the substrate.



11.

11. Install the last boards carefully.

Apply glue at the recommended rate in the remaining area neatly.

Position all but the last row of boards carefully in the glue, and work into place.

Finally position the last row of boards, cut to fit the wall.

Close any gaps between the boards. Pack the boards off the wall if necessary and fix.



12.

12. Leave glued floors for the required curing time.

Manufacturers recommend different curing times. Follow their instructions.

Once the glue has cured, exposed nails can be removed or punched below the surface.

Protect the boards prior to sanding and finishing.

Plasterboard setting compounds can stain timber and silicone sealants and glues can affect the bond of the finish. Scaffolding, ladders, and dropped tools can dent timber significantly.

Cover the completed floor with cardboard, plastic and drop sheets.

